

```

1  FUNCTION_BLOCK SledFC302
2  VAR_INPUT
3      Enable : BOOL ;
4      PositionRef : DWORD ;
5  END_VAR
6  VAR
7      DWORD_AS_WORD_0 : SE_TBX . DWORD_AS_WORD ;
8      TON_0 : TON ;
9  END_VAR
10 VAR_OUTPUT
11     SledError : BOOL ;
12 END_VAR
13

```

1 *Activates Homing. But homing mode is set to 1, that means 0 is the actual position.*

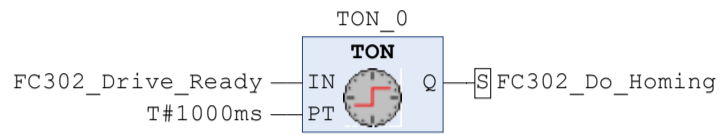

2 *Sending ref position to Danfoss FC302*

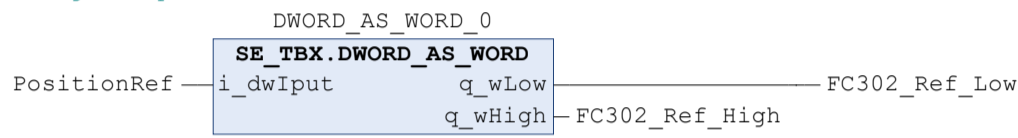

3 *RUN Command FC302*

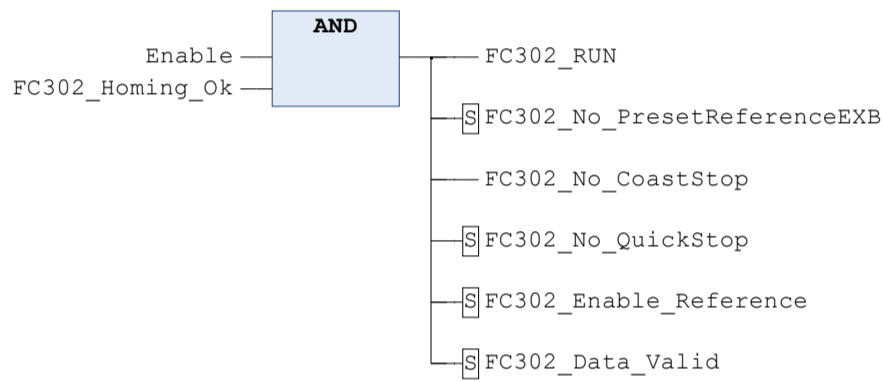

4 *Set max speed*



5 *Fail indication*

